



USER MANUAL

ICP 400



ICP 400

WARRANTY

Refer to the warranty notice supplied with your printer for warranty terms and conditions and limitations.

ENVIRONMENTAL INFORMATION

Altec is committed to helping the environment by reducing the energy consumption of its products.

RECYCLING OF END-OF-LIFE PRODUCTS

The manufacture of the equipment that you have purchased required the extraction and use of natural resources. It may contain materials that are hazardous to health and the environment. To prevent the dispersal of such materials into our environment and reduce the pressure on our natural resources, we recommend that you use existing collection systems. These systems will appropriately re-use or recycle most of the materials in your end-of-life equipment.



The crossed-out dustbin symbol on your device is a reminder to use these systems.



ICP 400

ABOUT YOUR NEW PRINTER

Thank you for choosing an Altec printer. Using your new printer, you will be able to create a wide variety of high-quality cards and badges which can be printed in various thicknesses, colours and styles. This printer uses consumables and accessories available from Altec.

GETTING STARTED

The purpose of this user guide is to guide you, step by step, through your printer and how it works. Take some time to read it in order to better understand your printer and its features, and to save time during installation and use.

As with all Altec products, a great deal of care has been taken over this manual. Should you find an error, however, please let us know by emailing us at info@altec.nl.



Carefully read this manual.

CONTENTS

The bookmarks found top left of your screen can be used to navigate between the various sections in this user guide.

ICONS

The following icons are used in this manual to highlight important information:



Information providing further details or depth about certain points in the main text.



Indicates that failing to take the recommended action is liable to damage your printer.



This symbol links to Evolis Print Center, accessible from your computer, which you can use to administer and manage your printer and change its settings.



ICP 400

1 – GETTING STARTED

UNPACKING

Your printer is supplied with several accessories that we ask you to look at closely. This list may vary depending on your location.

The printer is shipped in special packaging designed to prevent any damage in transit. If you notice any visible damage, do not hesitate to contact the shipper and immediately inform Altec, who will tell you the procedure to follow.

Altec takes great care over the quality of its packaging and we ask that you keep this packaging somewhere clean and dry.



You will be asked for the full original packaging (outer box, inner wedges and protective bags) in the event that the printer is returned. If the printer is returned without its original packaging and components are damaged in transit, these components will no longer be covered by the warranty. You will be charged for new packaging for shipping the printer back to you.

Accessories supplied with your printer:

- Power supply unit – SWITCHBOX type F10723-A, CWT type KPL-065M or CWT type KPL-065M-VI
- Mains power cable.
- USB cable.
- Reject box.
- Installation, documentation and software CD-ROM.
- Starter cleaning kit.
- Quick installation guide.
- Warranty notice.



If any of these components are missing, please contact Altec.
Use only the power supply unit supplied with your ICP-400 printer.
SWITCHBOX type F10723-A, CWT type KPL-065M or CWT type KPL-065M-VI.
Use only the USB cable supplied with your ICP-400 printer.



The ICP-400 printer must be placed in a dry location, protected from dust and drafts but well-ventilated. Take care to keep your printer on a flat, sturdy surface able to bear its weight.



ICP 400

DESCRIPTION OF THE PRINTER AND ITS FUNCTIONS

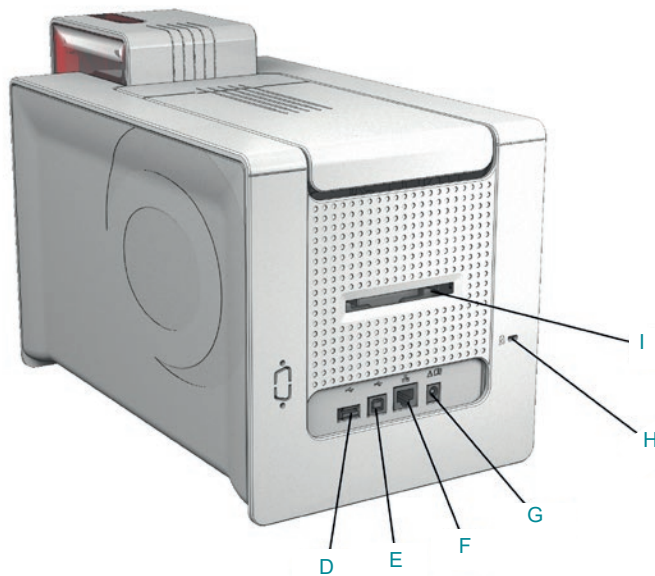
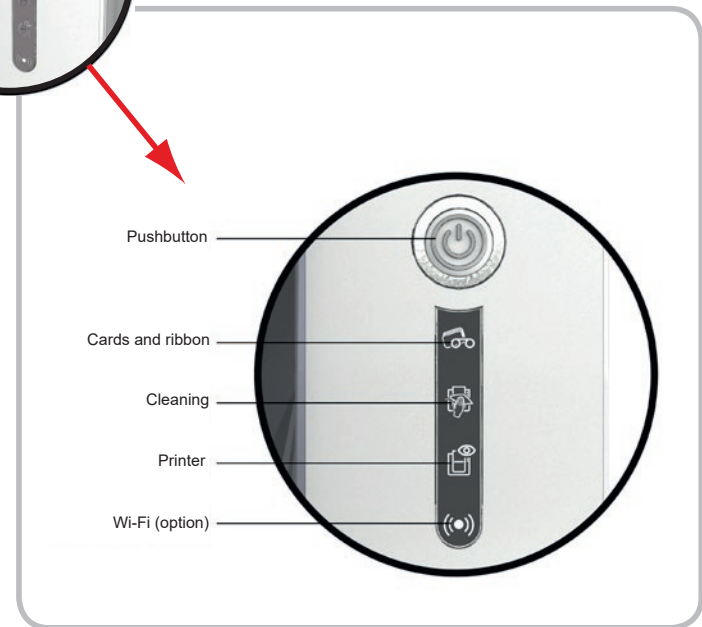
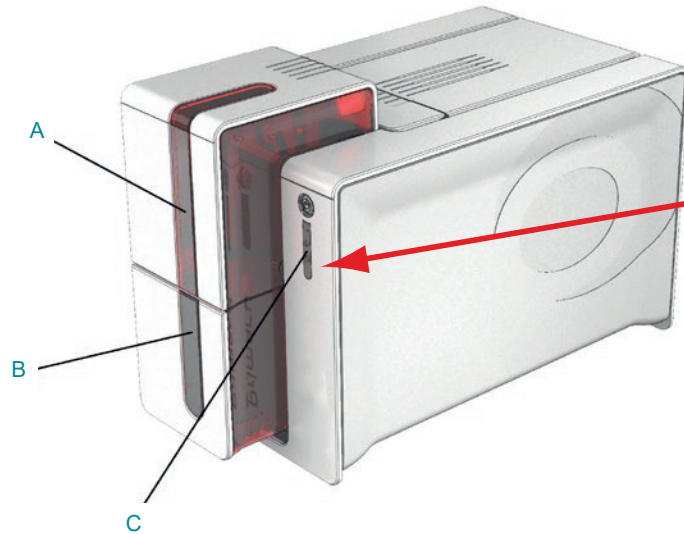

- A – Card input feeder
- B – Output hopper
- C – Control panel
- D – USB socket (type A)
- E – USB socket (type B)
- F – Ethernet connector

- G – Power cable socket
- H – Place for Kensington lock
- I – Place for reject box/rear hopper



ICP 400

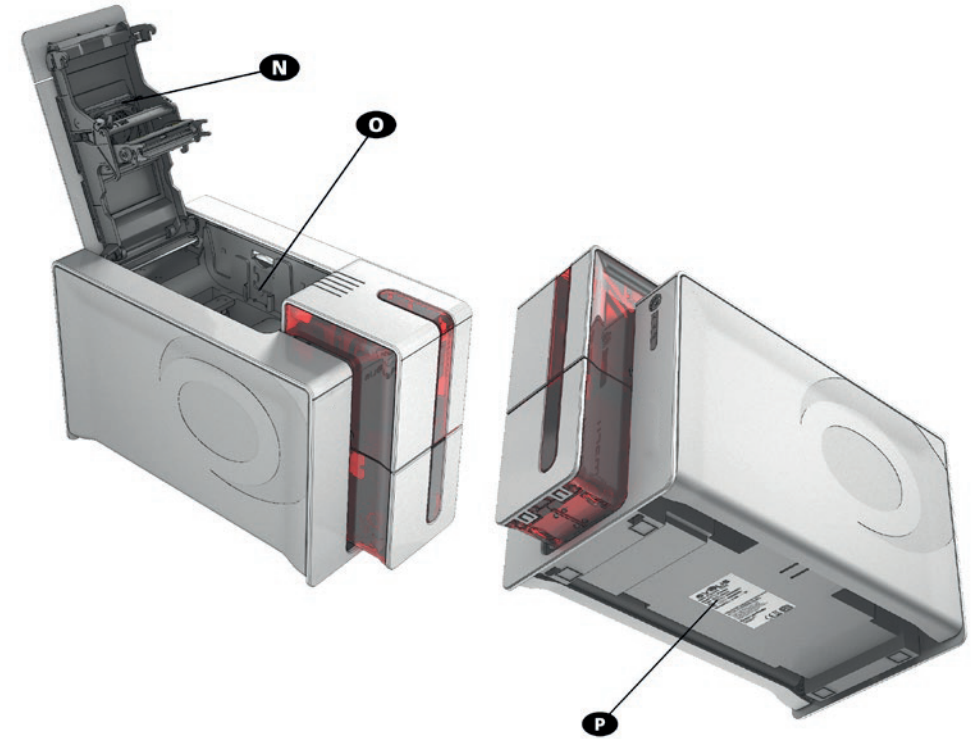
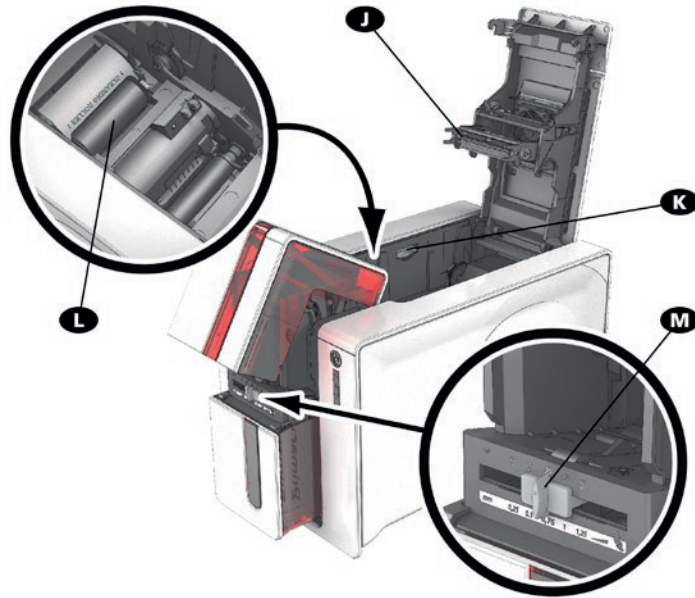

- J – Thermal print head
- K – Side panel opening mechanism
- L – Cleaning roller
- M – Card thickness adjustment gauge

- N – Dust filter
- O – Location for double-sided printing activation key
- P – Serial number label



Your machine may be supplied with an LCD screen instead of the control panel; please refer to LCD screen user guide to find out how to operate it.



Access to the side panels of the machine and the option module fitting/removal areas is restricted to your retailer/installer or to experienced users. The machine should always be disconnected from the power supply (unplugged) before carrying out any work on it.



INSTALLATION

Connecting the printer

Connection to the power supply



The printer must be connected to a properly protected and earthed electrical installation.
FI: Laite on liitettävä suojamaadoitus koskettimilla varustettuun pistorasiaan.
NO: Apparatet må tilkoples jordet stikkontakt.
SE: Apparatens skall anslutas till jordat uttag.
DK: Printerens skal tilsluttes til en korrekt beskyttet og jordforbundet el-installtion.

- Connect the power cable to the power supply unit, then plug the power supply unit connector into the printer.
- Next, plug the end of the power cable into an earthed power socket.
- The printer is powered on: the control panel lights up showing the printer is working properly. If the control panel does not light up, then either installation has not been carried out correctly or the printer is not working properly. Check the installation.



Before attempting any maintenance, always ensure that the power cable is unplugged. For your personal safety, ensure that the cable and power supply unit remain easy to access, especially in the event of an emergency.



To save energy, the printer will automatically switch itself to standby mode after 10 minutes of inactivity. The printer switches to hibernation mode after 30 minutes in standby mode.
The standby times can be configured in the Print Center. In standard standby mode, sending a print request restarts the printer and quickly pressing (for 1 second) on the button exits the printer from hibernation mode.

Connecting the USB cable



Under no circumstances should you connect the USB data cable before installation of the printer driver is complete.

Refer to the section on printer driver installation for further details, and follow the instructions carefully.



ICP 400

Ribbons

Altec ribbons optimise your printer's operation and avoid causing damage to it. The use of ribbons from other suppliers is liable to damage your printer and voids the manufacturer's warranty for the printer.

For optimum print quality, Altec recommends that the printer is fully cleaned every time the ribbon is changed.

Fitting the ribbon



The printer automatically recognises the ribbon inserted.

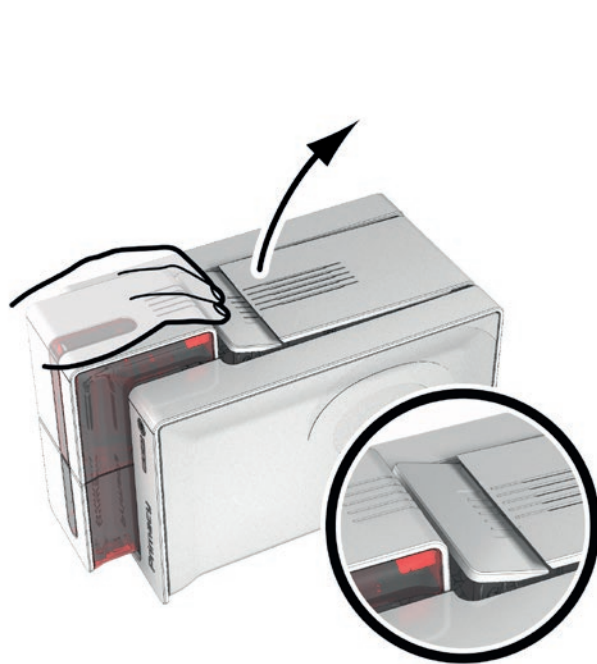

Open the cover.

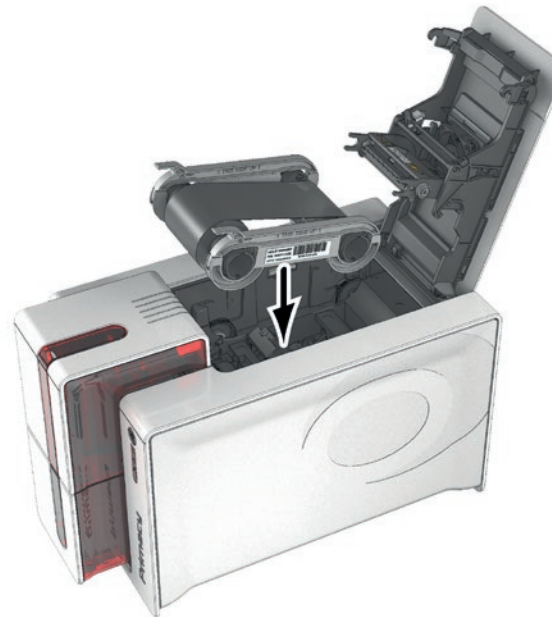

Insert the ribbon as shown.



Close the cover and press until a click is heard.



ICP 400

Cards



Use only the card types recommended by Altec.
Do not touch the printable surface of the cards in order to preserve print quality. Do not use cards that have been damaged, folded, embossed or dropped on the floor. Keep your cards protected from dust.

Loading the cards

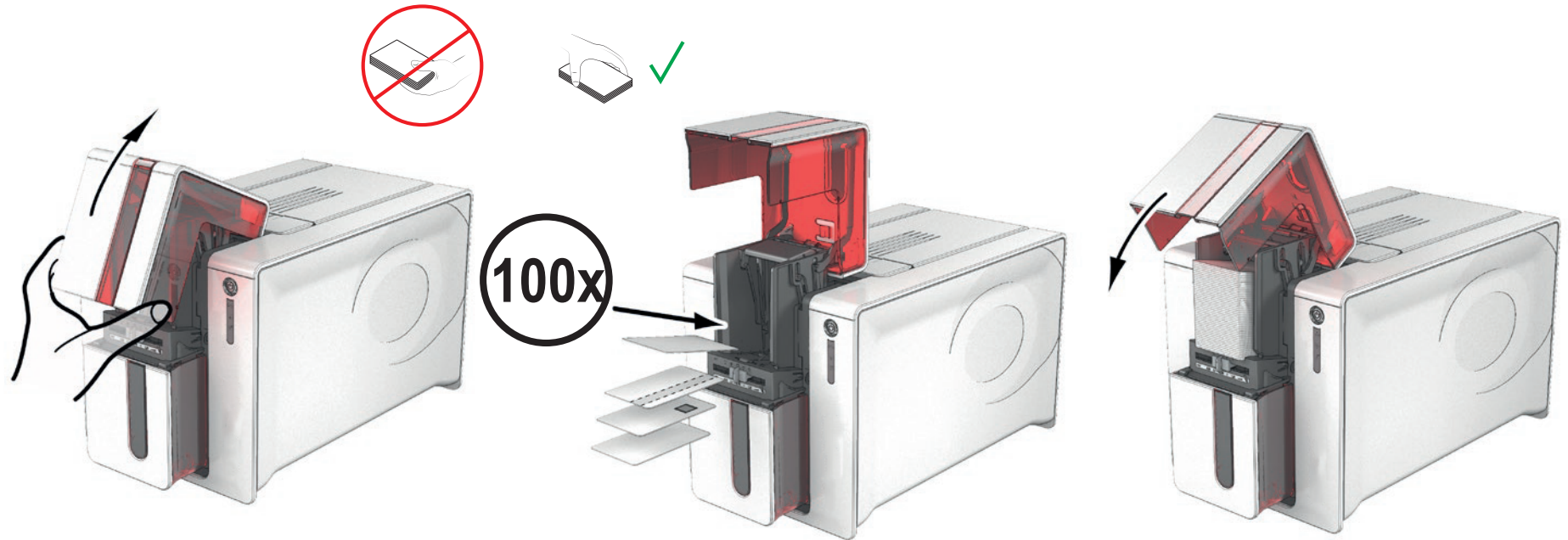

Open the card feeder.

Insert the cards, a maximum of 100 cards of thickness 0.76 mm. Ensure the cards are positioned as illustrated in the diagram.

Close the feeder.



ICP 400

Removing printed cards

Once the print cycle is complete, cards are delivered into the output hopper below the card feeder. This output hopper is designed to collect the printed and/or encoded cards. The printer is equipped with an output hopper with a maximum capacity of 100 x 0.76 mm cards.

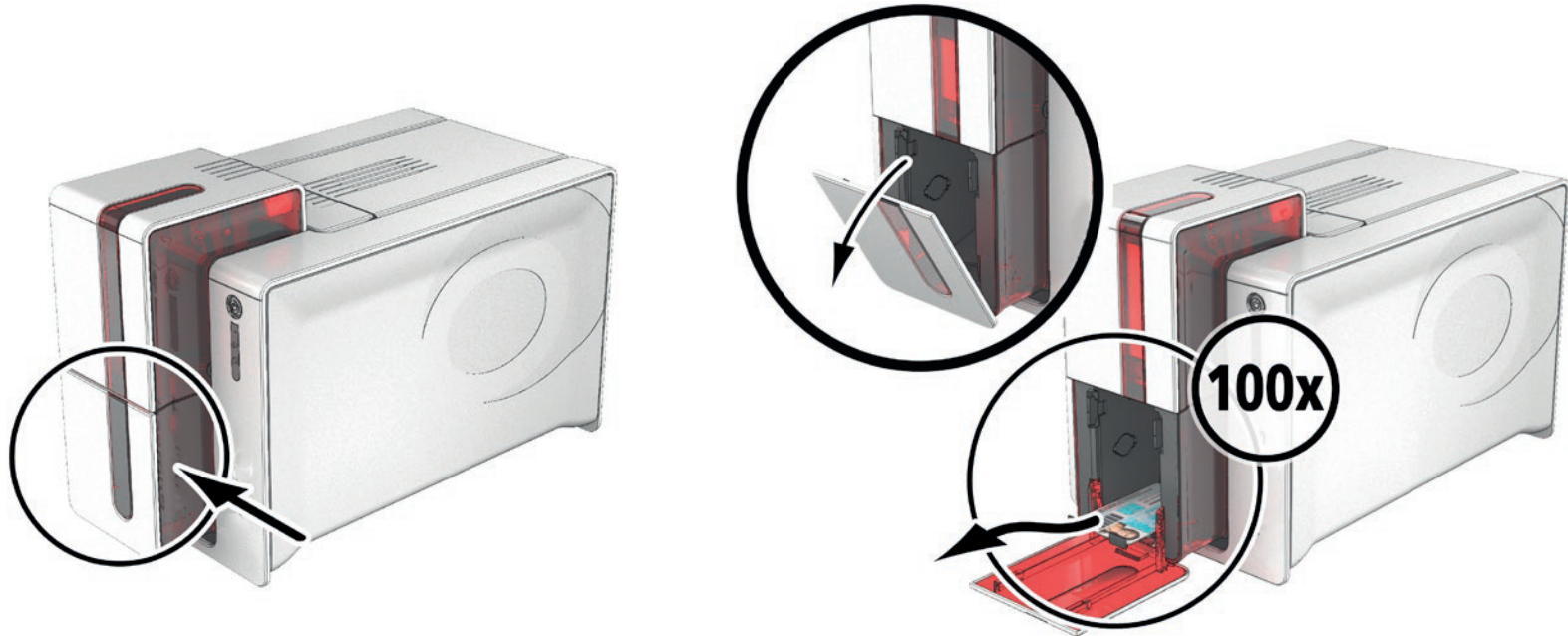

Adjusting card thickness

The printer is equipped with a manual card thickness adjustment mechanism which can be reached through the card feeder when open. The printer accepts cards between 0.25 mm and 1.25 mm thick (10 to 50 mil). The factory setting is 0.76 mm.



ICP 400

To adjust card thickness:

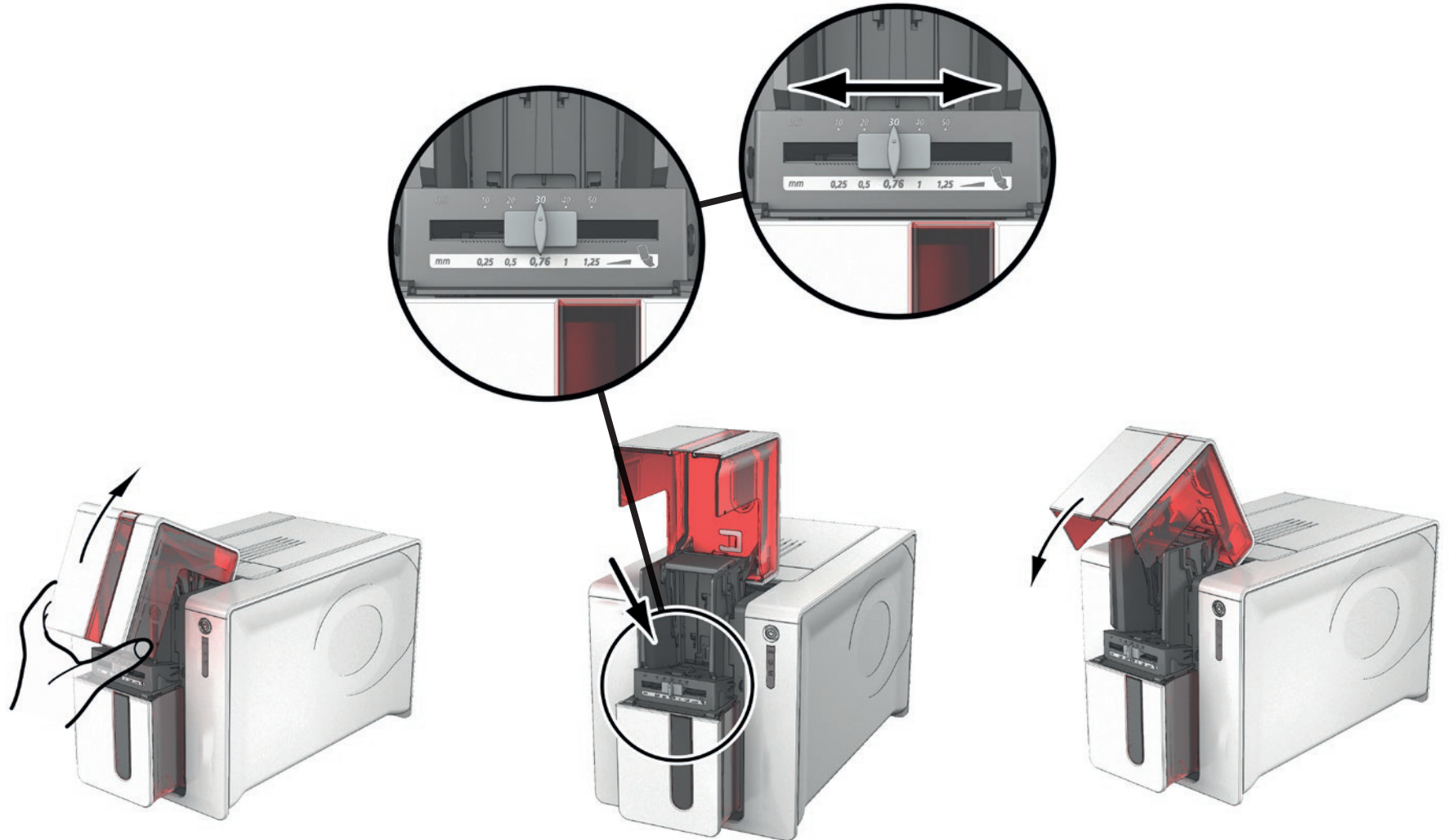

Open the card feeder on the printer.

Adjust the thickness of the cards used by moving the gauge from right to left to the desired card thickness.

Then close the feeder.



ICP 400

Managing the reject box/rear hopper

The printer is fitted with a removable reject box which is positioned behind it. The reject box can hold 50 cards (0.76 mm - 30 mil). To empty it, simply open the box and remove the cards in it. Altec recommends that you empty this box regularly.

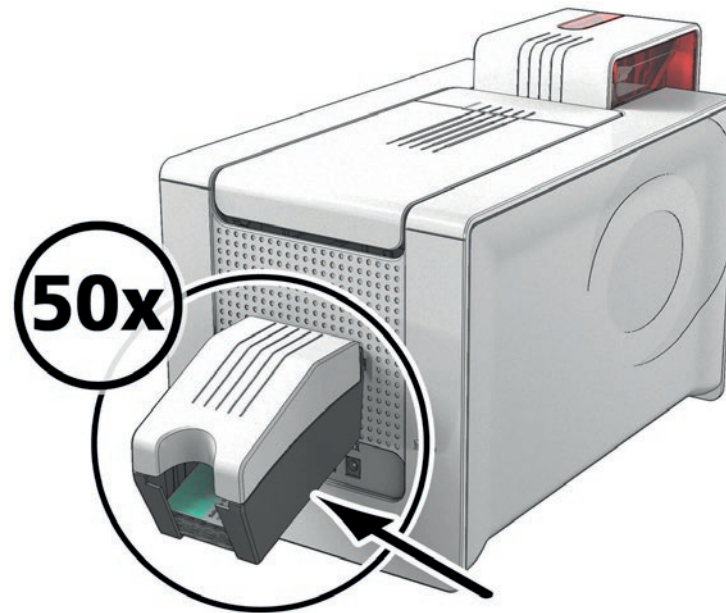

The reject box can be used as a hopper to optimise the production flow of cards when continuous ribbons are used.



Preloading cards to optimise the production flow is activated in the Print Center. Double-click the printer name, then click **Printing**, then **Feeder/Hopper**.



ICP 400

2 – PRINTING

INSTALLING THE PRINT DRIVER

Advanced functions automate printer configuration after the print driver has been installed. Your printer is delivered with a CD-ROM comprising the Premium Suite[®], which contains the print drivers for Windows.

The Premium Suite[®] is an all-in-one driver software solution, which enhances the user experience by making the interactions between printer and computer more intuitive.

It includes:

- A print center that supervises the printers: printer status information, remaining ribbon capacity, etc.
- A powerful tool for printer settings
- A notification centre to alert users when their intervention is required
- A printer management and maintenance station
- A series of assistants to guide you through cleaning and encoding operations, etc.
- An encoding station (magnetic encoding, etc.)
- A diagnostic tool

To install the print driver:

Insert the CD-ROM into your computer and select the print driver menu. A programme will guide you through the entire installation process.



Do not connect your USB cable to your computer until prompted to do so by the installation programme. For the connection procedure, see the section on Connecting the printer.



Follow the installation procedure scrupulously. All versions of Windows require the user to have administrator rights to install the driver.



ICP 400

MANAGING THE PRINT SETTINGS

Once the ribbon has been installed, your ICP-400 printer will automatically adapt its parameters and settings to suit the ribbon. A graphic application called Print Center is available to help you if necessary to change certain predefined settings.

To access this application:

- From the **Start** button on the bottom left of your screen in the Windows task bar, select **All programs, Card Printer, Premium Suite, Print Center**.
- The application displays all connected Altec printers.

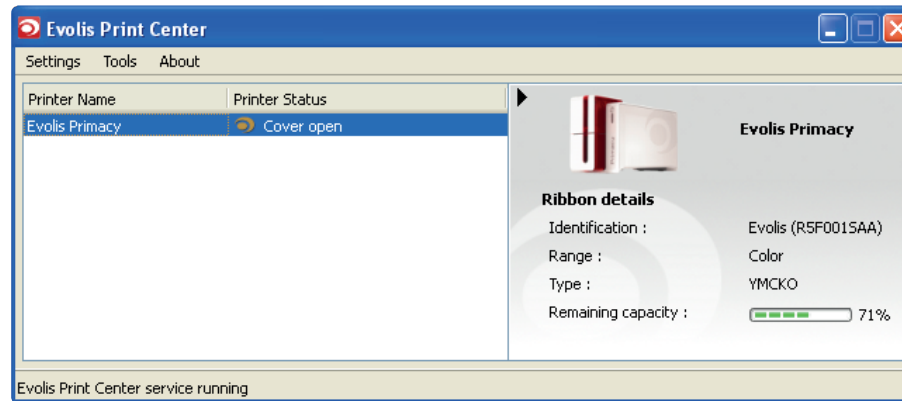



- Select the desired printer.
- Right-click the name of the printer, select **Properties** to access the settings or double (left) click the name of the printer.

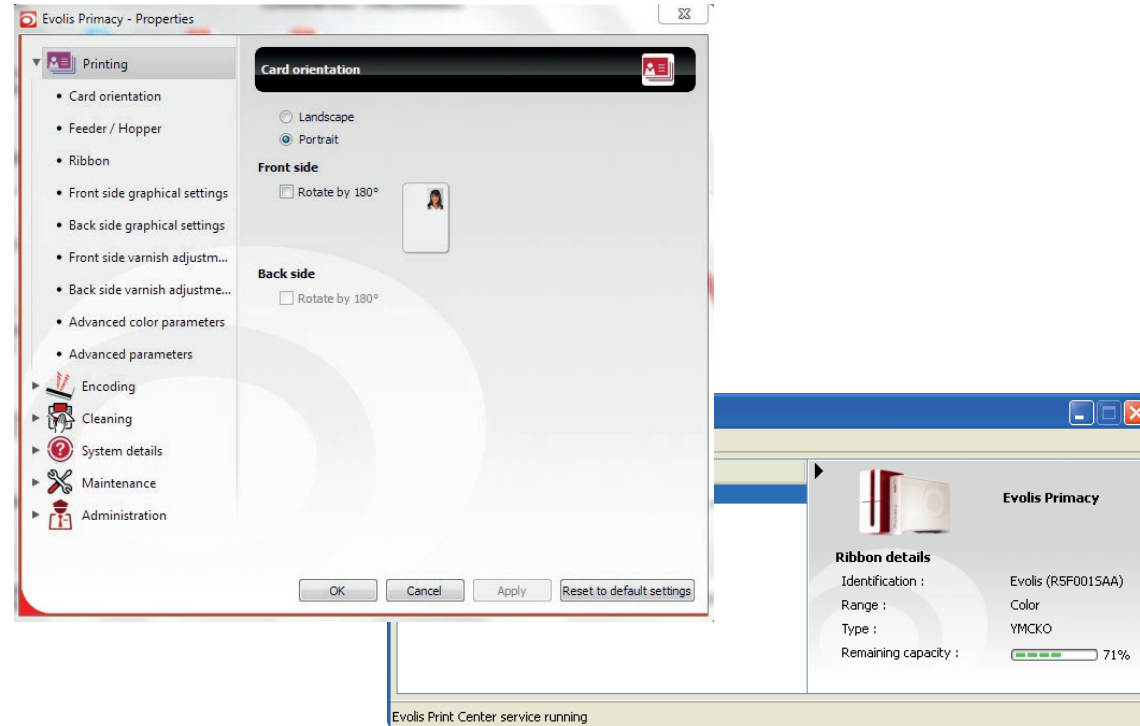

Pay attention to the settings defined under the print driver Properties and do not hesitate to contact Altec for any advice and assistance needed before making any changes.



Please refer to the Print Center manual for more detail about the meanings of each of the settings.



NOTIFICATION OF MESSAGES AND WARNINGS

The Printer Manager has an additional function allowing the printer to communicate with the user with notifications. There are several types of notifications:

- Messages about the maintenance of the printer.
- Messages and alerts associated with the ribbons, their compatibility with your printer or the nature of your print requests.
- Warnings about problems which have stopped the printer.

When the **Printer Manager** is active, a small icon is displayed in the bar on the bottom right of your screen.



The colour of the icon varies according to the status of the printer:

- Green: Printer ready
- Orange: Information message issued – printing stopped
- Red: Warning message issued – printing stopped
- Grey: Printer in hibernation mode, disconnected or communication interrupted.

When a notification is issued, it is displayed in a window of the following type:

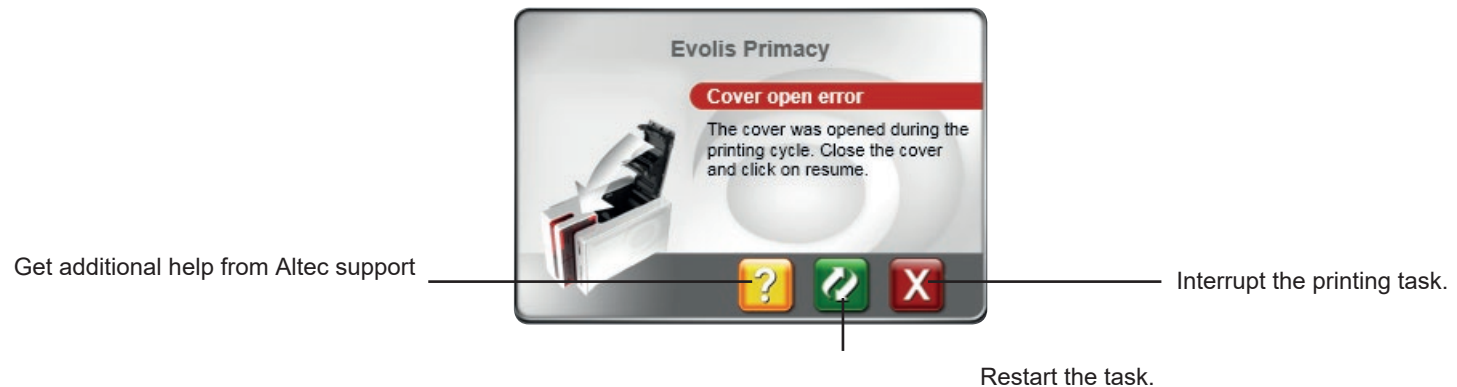

The **Printer Manager** service can be disabled by right-clicking the icon on the status bar.



Interrupting the Printer Manager service is only recommended if there is a conflict with other applications installed on your computer. The Printer Manager service is the best way of monitoring your printer effectively from your workstation.



ICP 400

CONNECTING TO A NETWORK (ETHERNET AND WI-FI)

All Altec printers can be fitted with a TCP/IP network connection. This function is available as standard on ICP-400.

Out of the box, the printer comes configured in DHCP mode (Dynamic Host Configuration Protocol), which means that its IP address is supplied by the network. In addition to these basic settings, the network administrator has the option of configuring the printer differently in order to comply with the constraints imposed by the corporate LAN:

- Printer connected in a subnet, in DHCP mode
- Printer connected to a subnet in fixed IP address mode, with WINS resolution
- Printer connected to a subnet in fixed IP address mode, without WINS resolution

The printer may be identified on the network in two ways:

- By its hostname (NETBIOS)
- By its IP address

In addition, the Ethernet connection wizard will automatically detect all installed Altec printers.

The user-definable settings are:

- IP address of the printer
- Subnet mask
- Gateway
- WINS server



Altec printers fitted with a TCP/IP network interface have an embedded http server.



Changing the printer's basic settings without prior knowledge of the layout of the LAN in question or without genuine technical knowledge may result in a malfunction of the printer, and may even extend to more widespread failure of all or part of the LAN. Contact your System and Network Administrator before connecting to or changing the settings for your local area network.



For further details, refer to the "Configuration of Altec printers on a TCP/ IP (Ethernet) LAN" manual.



ICP 400

3 – MAINTENANCE

GENERAL WARRANTY INFORMATION

Your Altec ICP-400 printer has been designed to give you long service and needs only minimal regular maintenance. Please comply with the instructions given below to ensure that it runs satisfactorily.

Keep your warranty cover!



The manufacturer's warranty is subject to strict adherence to the routine servicing and maintenance instructions, and in particular the printer cleaning cycles.

Any failure to follow the maintenance and servicing procedures described in this section voids the print head warranty.

Altec declines any liability where there has been a failure to carry out required maintenance on the printer.

The print head is a wearing part and an extremely sensitive printer component. Its useful life can be seriously curtailed by the presence of dust, liquids or solids in the printer's immediate environment, on the print head or on the cards. Users must take all necessary precautions to insert only clean cards, free of dust deposits or foreign bodies, into the machine.

The frequency and quality of cleaning are decisive factors enabling users to extend the print head's useful life and to ensure excellent print quality. Particular care must therefore be taken with cleaning. Users must comply with the servicing and maintenance instructions as fully described in this section.

In addition, the use of Altec brand ribbons also ensures that your equipment operates properly. Use of ribbons not approved by Altec may as a consequence affect the quality and reliability of print jobs, produce low quality printed output and even affect the printer's operation. The manufacturer's warranty does not cover physical damage or quality problems caused by using non-Altec approved ribbons.



ROUTINE PRINTER CLEANING

Printer cleaning



The print head warranty is directly linked to routine cleaning of your printer.
If you do not carry out this cleaning at the required times, the print head warranty will cease to be valid.



Recommended cleaning cycle: whenever the ribbon is changed.
Mandatory cleaning cycle: when the cleaning warning is triggered.
Servicing accessory: adhesive cleaning card.



Your printer is fitted with a cleaning warning system which is triggered after a certain number of cards have been inserted.
You should proceed with the routine cleaning of your printer as soon as the warning is triggered.
If you continue to run the printer despite the warning and if the warning light remains lit, the print head warranty will be automatically voided owing to a failure to comply with your contractual maintenance obligations.

Printer	Cleaning required after: (warning light flashing)	Number of cards remaining before warranty voided: (warning light flashing)	Warranty invalid after: (warning light steady)
ICP-400	1000 cards	200 cards	1200 cards



ICP 400

Follow the procedure below to ensure you have carried out regular cleaning properly:

Repeatedly running the adhesive card through the printer cleans the cleaning roller in order to maintain print quality and increases the service life of the print head.

- 1 Open the printer cover.
- 2 Remove the ribbon as shown on the diagram.
- 3 Close the cover and check it has clicked shut.
- 4 Open the card feeder on the printer.
- 5 Using the lever, set the card thickness to the MAX position.

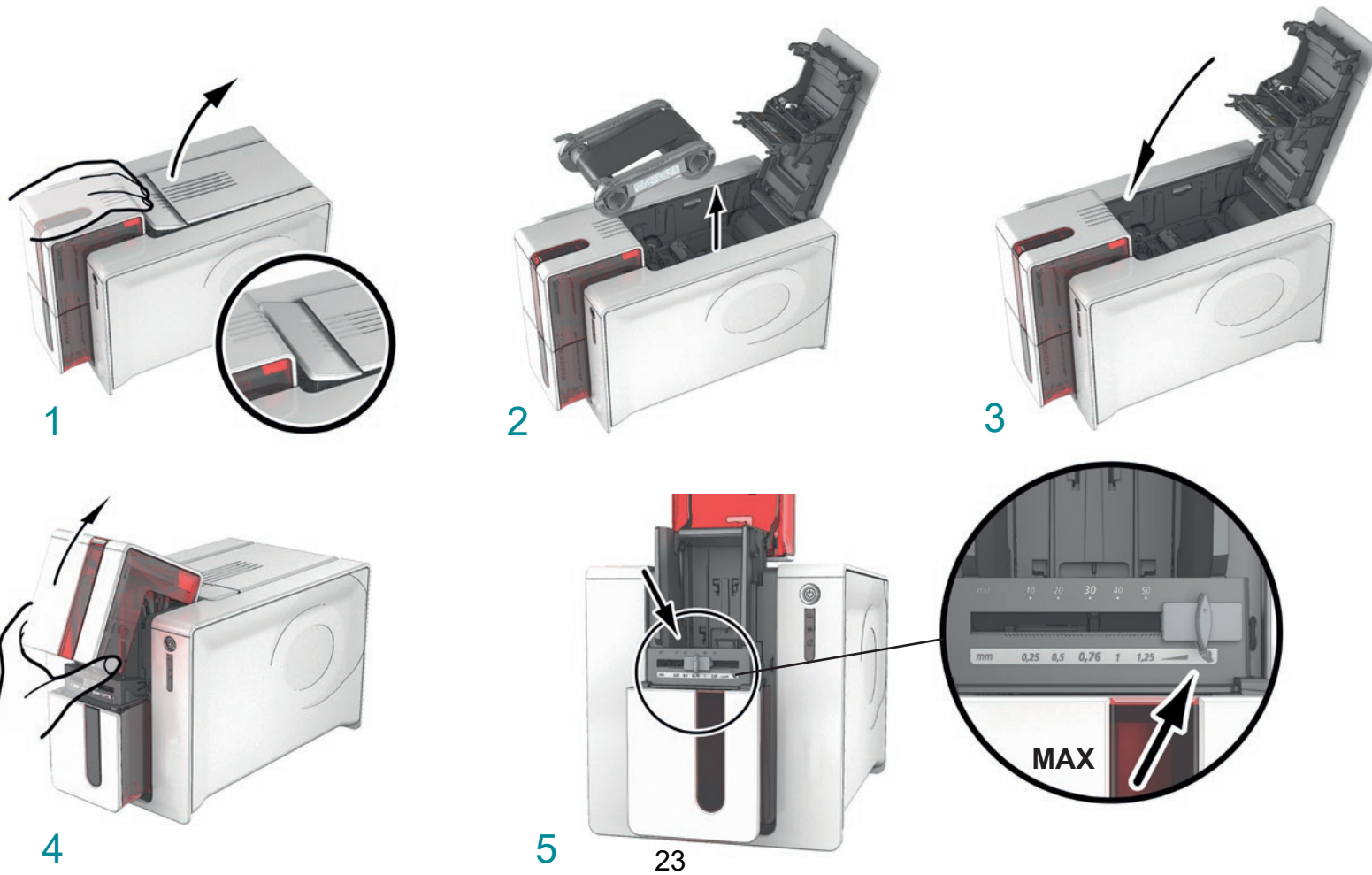



ICP 400

- 6 Remove any cards present in the feeder.
- 7 Double-click the cleaning button on the control panel before inserting the cleaning card.
- 8 Remove the film from the adhesive card ① and insert the cleaning card into the feeder as shown, adhesive side up ②. Cleaning starts.
- 9 The used cleaning card is ejected automatically into the output hopper.

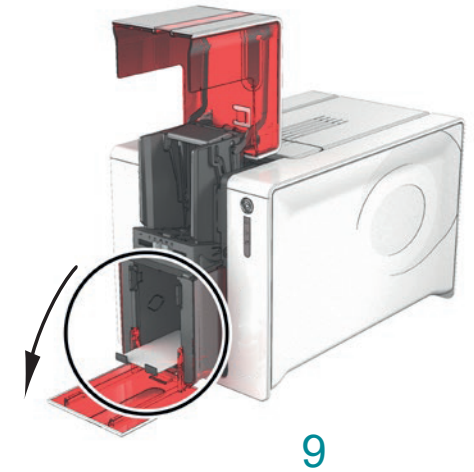
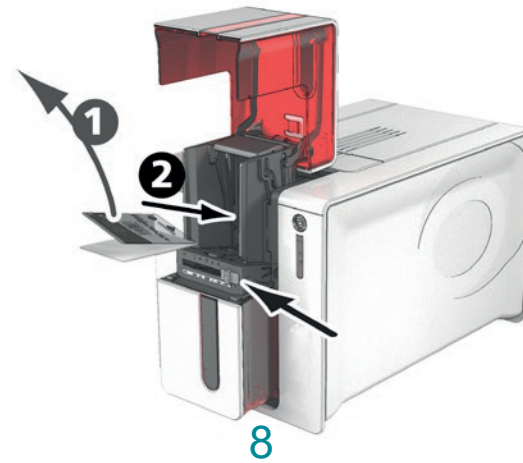
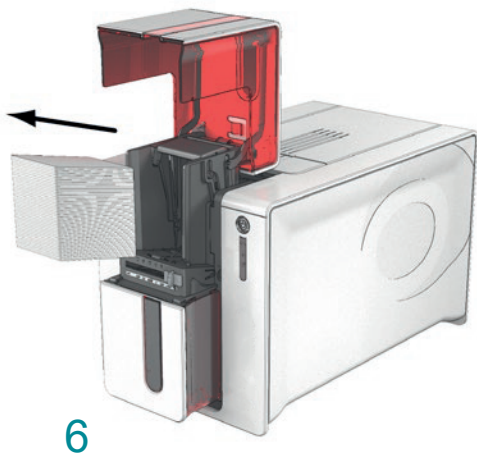

Routine cleaning may also be carried out from the Print Center by clicking on “Start cleaning”.



Before using your printer, remember to reset the gauge to the desired card thickness.



ICP 400

Servicing the print head



Recommended cleaning cycle: whenever the ribbon is changed.
Servicing accessory: special cotton bud impregnated with isopropyl alcohol.

To maintain the original print quality and to absorb surplus ink on the print head, we recommend that you regularly clean the print head (whenever the ribbon is changed and during the routine cleaning) using the cotton buds supplied by Altec. You must also protect the print head and its components from any discharge of static electricity.



Unplug the printer from its power supply before cleaning the print head.
Follow the cleaning cycles scrupulously.
Avoid any contact between the print head and any metal or sharp objects.
Avoid touching the print head directly with your fingers, as this could affect print quality or permanently damage the print head.



ICP 400

Follow the procedure below:

- 1 Take an Evolis cotton bud and press the middle of the tube until the end of the cotton bud is impregnated with alcohol.
- 2 Unplug the power supply cable, open the cover then find the print head.
- 3 Gently rub the cotton bud from left to right along the print head for a few seconds.
- 4 Close the cover. Reconnect the printer.

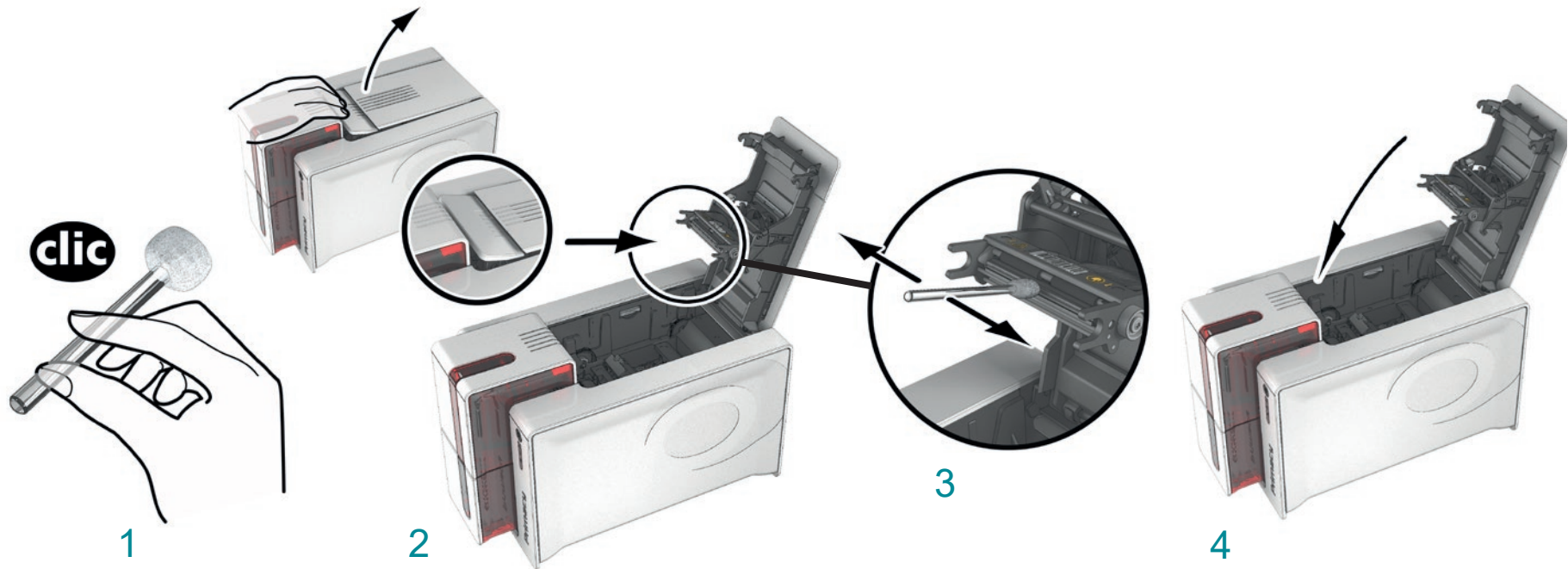

Wait for 2 minutes after cleaning before using your printer.



ICP 400

ADVANCED CLEANING

For a more in-depth clean, we recommend carrying out an advanced clean every five routine cleaning cycles. Altec provides an Altec ICP-400 maintenance kit consisting of 2 adhesive cards, 2 impregnated “T” shaped cards, a cleaning pen and a box of wipes. The “T” shaped card is used to clean the card feed rollers and the magnetic encoder head. To ensure advanced cleaning is carried out properly, the procedure given below must be followed.

Printer cleaning



Recommended cleaning cycle: every 5 routine cleaning cycles. Servicing accessory: impregnated “T” shaped card and adhesive card.

Follow the procedure below:

- 1 Open the printer cover.
- 2 Remove the ribbon as shown on the diagram.
- 3 Close the cover and check it has clicked shut.
- 4 Open the card feeder on the printer.

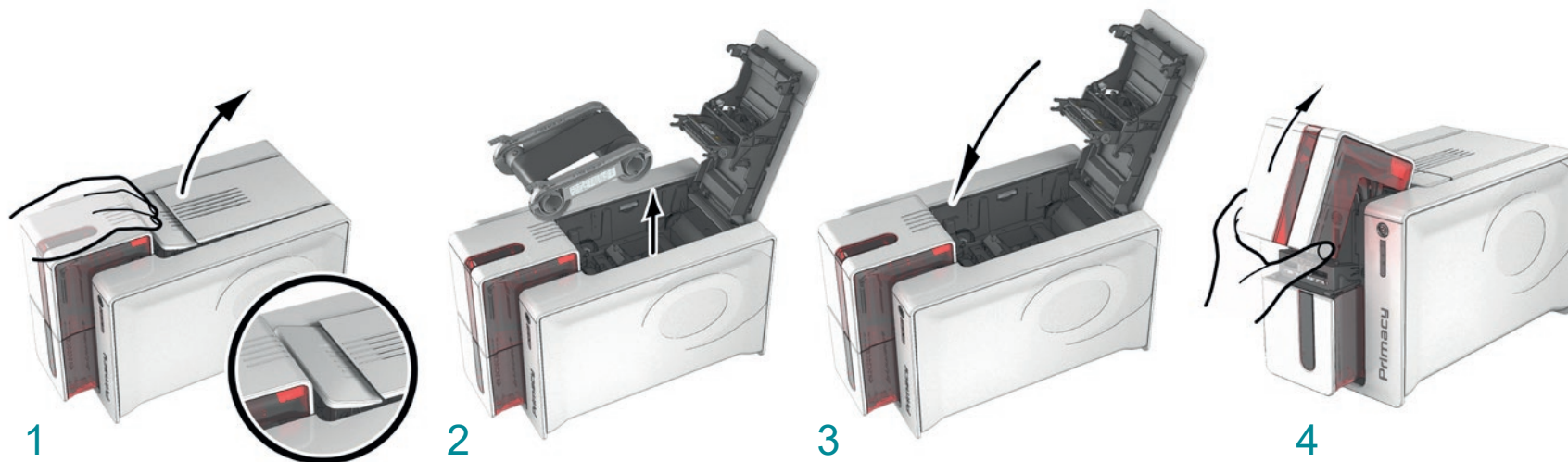



ICP 400

- 5 Using the lever, set the card thickness to the MAX position.
- 6 Remove any cards present in the feeder.
- 7 Double click the cleaning button on the control panel before inserting the cleaning card.
- 8 Take the “T” shaped cleaning card and insert it into the feeder as shown. Cleaning starts.

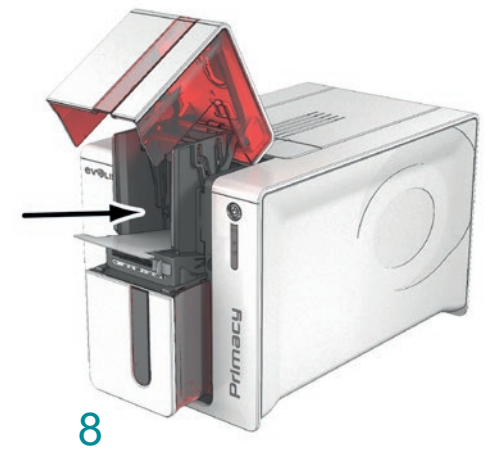
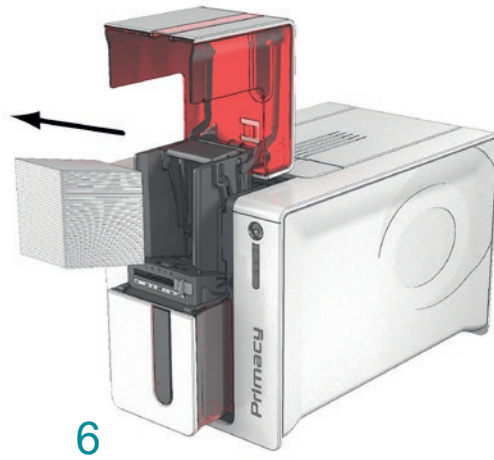
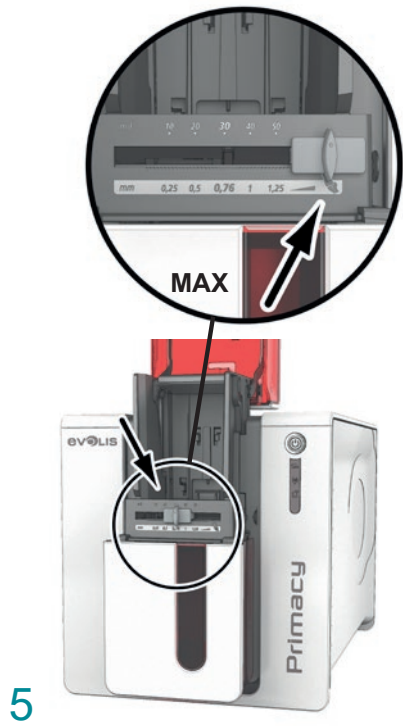



ICP 400

- 9 Remove the “T” shaped card, then remove the film from the adhesive cleaning card ① and insert the cleaning card into the feeder as shown, adhesive side up ②. Cleaning starts.
- 10 The used adhesive card is ejected automatically into the output hopper.

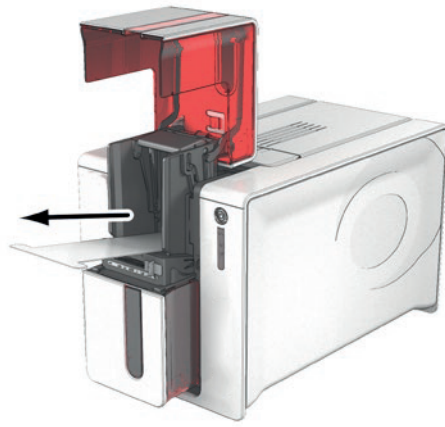

9

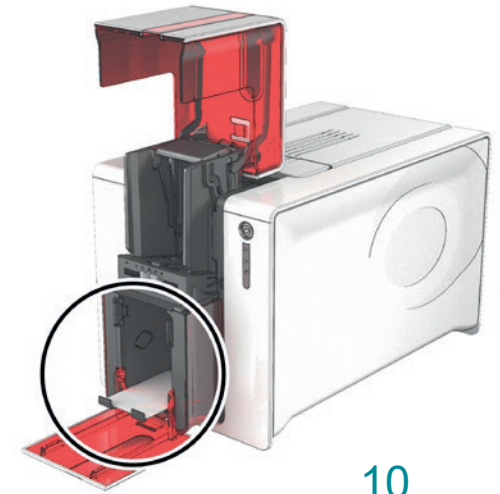
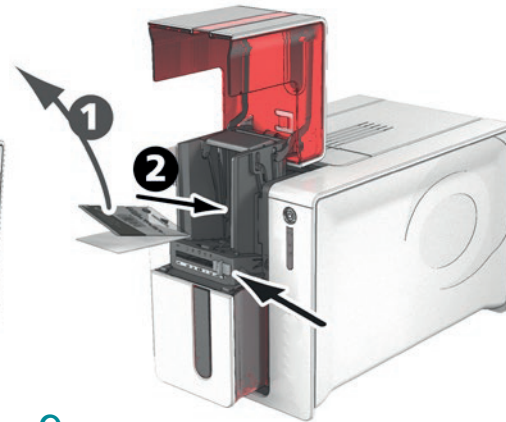

10



Routine cleaning may also be carried out from the Evolis Print Center by clicking on “Start cleaning”.



Warning, the “T” shaped card must be used just after the sachet is opened.



Wait for 2 minutes after cleaning before using your printer. Remember to reset the gauge to the desired card thickness.



ICP 400

Servicing the print head



Recommended cleaning cycle: every 5 routine cleaning cycles.
Servicing accessory: cleaning pen



Unplug the printer from its power supply before cleaning the print head.
Follow the cleaning cycles scrupulously.
Avoid any contact between the print head and any metal or sharp objects.
Avoid touching the print head directly with your fingers, as this could affect print quality or permanently damage the print head.

The cleaning pen can be used up to 8 times for cleaning the print head. **Follow the procedure below:**

- 1 Remove the cover from the cleaning pen.
- 2 Unplug the power supply cable, open the cover then find the print head.
- 3 Gently rub the pen from left to right along the print head for a few seconds.
- 4 Close the cover. Reconnect the printer.

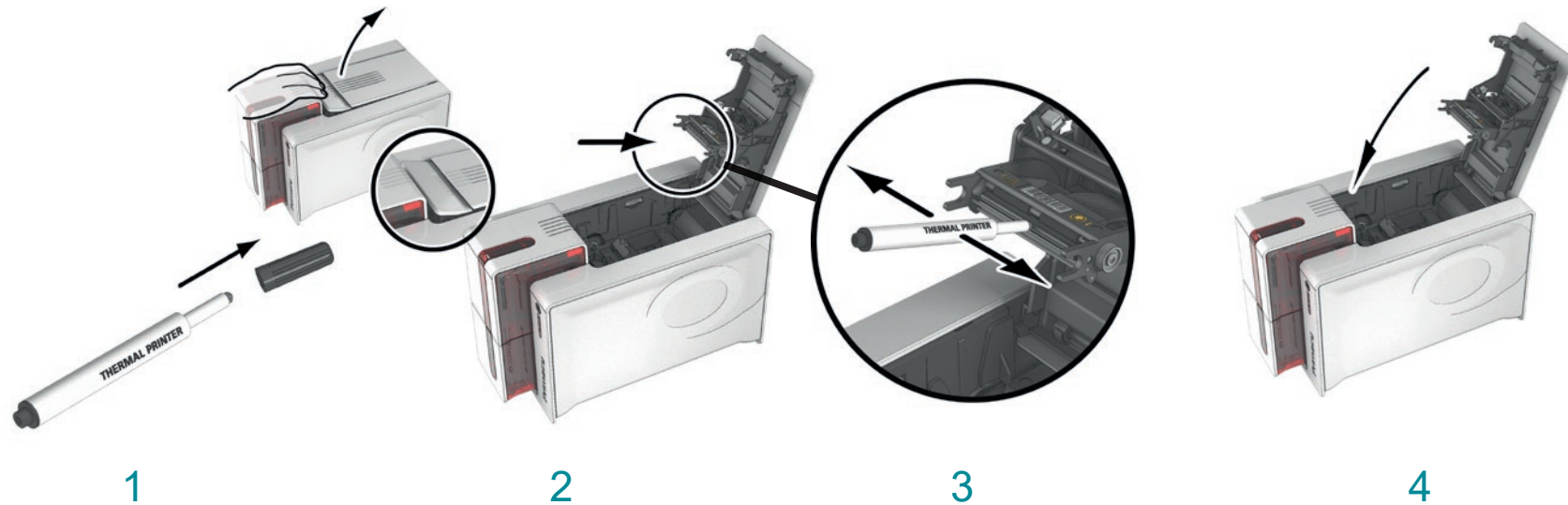

Wait for 2 minutes after cleaning before using your printer.



ICP 400

Servicing the dust filter

The dust filter is located above the print head fan. This filter can become fouled up over time and it is recommended to clean it once a year or every 10,000 cards depending on your working environment.

- 1 Open the printer cover. Locate the dust filter.
- 2 Remove the filter by pulling it upwards and slide it out to release it fully.
- 3 Once the filter is removed from its slot, take a cleaning wipe supplied by Altec.
- 4 Clean the filter by rubbing the wipe over both sides.
- 5 To replace it, insert it in its slot (notch towards you) and lower it until you hear a click confirming that it is firmly in place.
- 6 Close the cover.

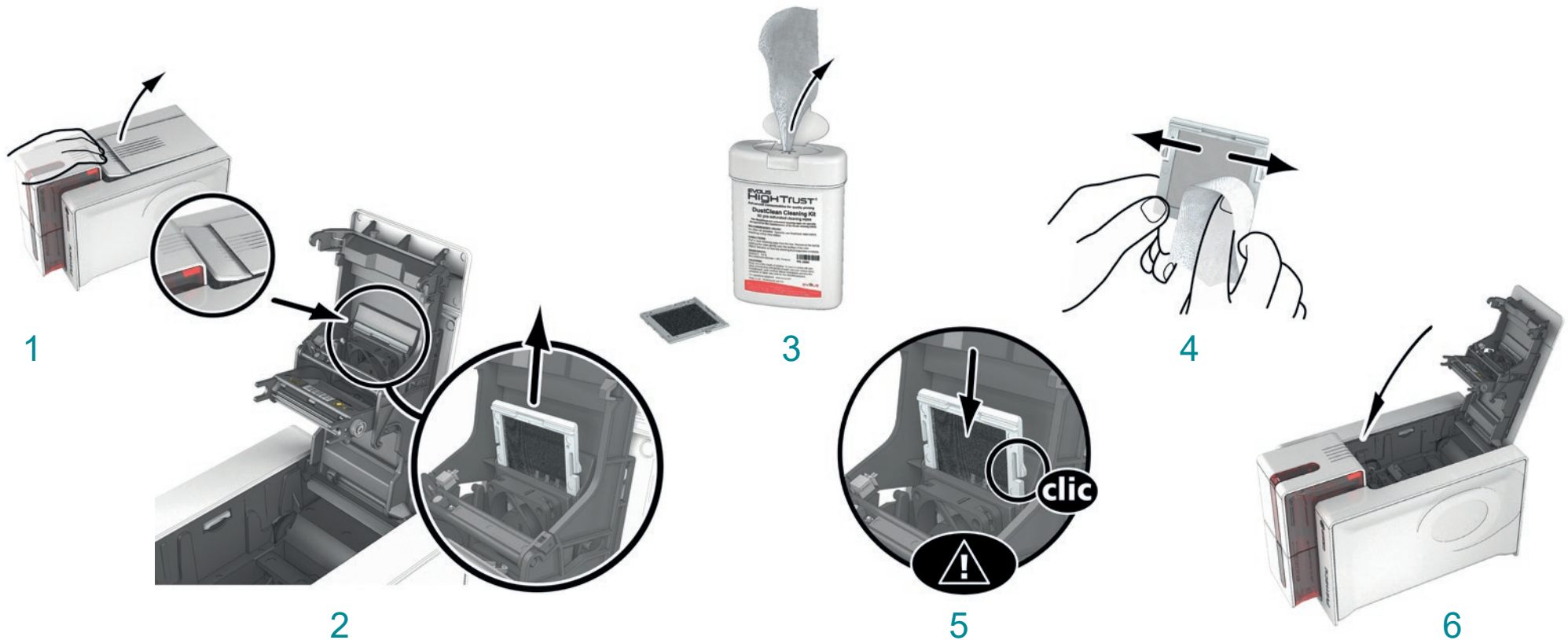



ICP 400

4 – HELP

This section gives a number of suggestions for identifying problems that may arise when using your printer. If you do not manage to solve your problem, this section also explains how to contact Altec technical support.

WARNINGS AND DIAGNOSIS

Although the ICP-400 printer was designed to work independently, keeping user involvement to a minimum, it may nonetheless prove useful to gain some familiarity with the main warnings.

Control panel warnings

See **section 1 – Description of the printer and its functions (p.5)** for further details about the control panel.

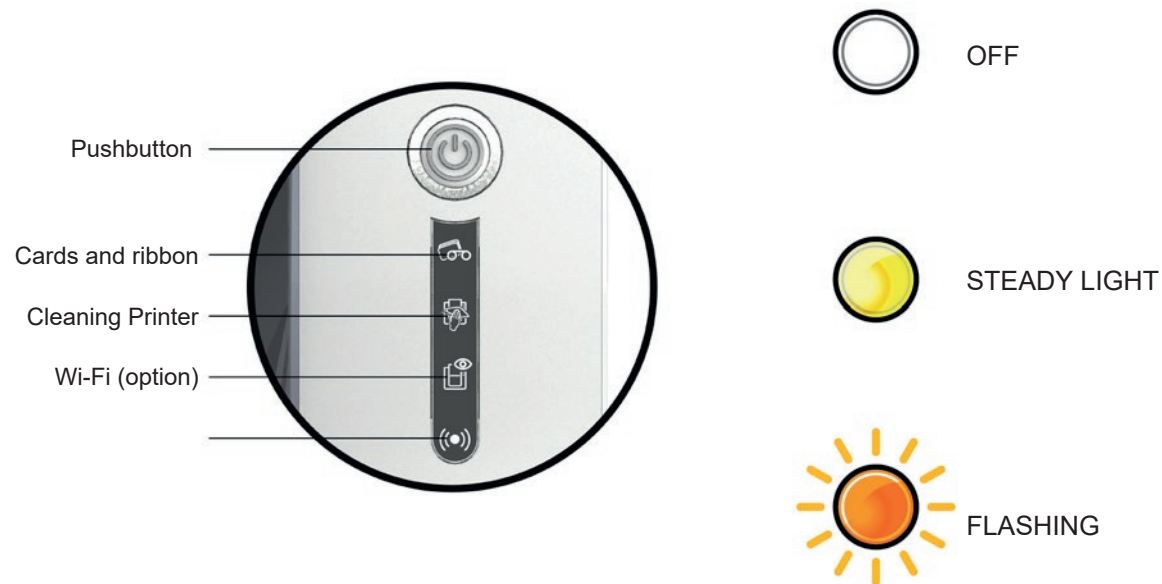

Your machine may be supplied with an LCD screen instead of the control panel; please refer to LCD screen user guide to find out how to operate it.



ICP 400



PRINTER READY

- The printer is ready to receive data.



PROCESSING

- The printer is receiving data.



RIBBON

- No ribbon in the printer.
- End of ribbon.
- The ribbon is not correctly fitted.
- The ribbon is torn.
- The ribbon is not recognised.

Check the condition of the ribbon in the printer. If you have a print job in progress, this restarts with a new card.

CARDS

- No cards in the card feeder.
- Put cards back into the feeder – the process starts again.**
- Card loading error.

Check cards have been loaded. For any other problems contact Altec.



PRINTER COVER OPEN

- The printer cover is open.

Close the cover again. The printer starts up.

MECHANICAL ERROR

- Card jammed in the printer.
- Mechanical component fault.

Open the cover and hold down the pushbutton in order to eject the jammed card. For more details, refer to page 40. If the problem persists, contact Altec.



ICP 400



ROUTINE CLEANING
(after 1,000 cards have been inserted)

- The printer must be cleaned.



COOLING MODE

- The cooling system has been activated. The printer pauses for a few seconds and restarts once it has returned to its normal operating temperature.



Wi-Fi IS ON (option)

- The wireless (Wi-Fi) connection has been enabled. You can start printing.



CLEANING
(after 1,200 cards have been inserted)

- The printer must be cleaned to avoid the risk of the warranty being voided.



FIRMWARE UPDATE

- The printer is updating its firmware. The printer restarts following the update.



ICP 400

DIAGNOSTIC HELP

In this section, you will find all the information you need to carry out a few simple checks that you may be asked to run by Altec to help you as effectively as possible.

Printing a technical test card

The technical test card must be printed when you receive your machine to ensure your printer is operating correctly. This card shows various items of technical information concerning the machine (serial number, firmware, cleaning operations, print head, etc.). You may be asked for these by Altec.

Printing a technical test card

- 1 Wait for any current print jobs to finish.
- 2 Check that there is a ribbon and a card in the printer.
- 3 Press the pushbutton for four to five seconds until it goes out.
- 4 Press and hold down the pushbutton again.
- 5 The pushbutton light comes on.
- 6 Release the pushbutton once the light flashes.
- 7 The test card is printed (in colour if a colour ribbon is fitted in the printer, or monochrome if the ribbon is monochrome, and on both sides if the double-sided printing function has been enabled).
- 8 The printed card is ejected into the output hopper.



Printing the technical test card can also be launched from the Evolis Print Center.

Printing a graphic test card

The graphic test card is used to check the print quality in colour or monochrome, the offsets and whether the ribbon is synchronised correctly. To print the graphic test card, check first of all that a ribbon and a card are present in the printer.

Go to **Evolis Print Center**, select **System information** and click on the **Test cards** tab. Then click the **Graphic test card** button. The card is printed and the printed card is ejected into the output hopper.



Printing the graphic test card can only be launched from the Evolis Print Center.



ICP 400

Identifying installed software versions

You can directly identify the system versions installed (driver, setup, etc.):

- 1 In **Evolis Print Center**, double-click the name of the printer to display its **Properties**.
- 2 Click **System information**, then **System information**.



ICP 400

TROUBLESHOOTING



Do not attempt to use tools or other items to repair your printer in the event of problems, in case major damage is caused.

Printing problems

Nothing prints

- 1 Check the print driver**
Check that there is a print driver for your printer in the Windows configuration.
Check that the printer is selected as the default printer.
- 2 Check the printer's power supply**
Check that the power cable is correctly connected to the printer and to a working electrical socket.
Check that the printer is on and that the pushbutton is lit.
Make sure you are using the power supply unit supplied with the printer.
- 3 Check the USB cable**
Check that the USB cable is connecting the printer to your computer.
- 4 Check the ribbon**
Check that the ribbon is fitted correctly and that the cover is closed.
- 5 Check the cards**
Check that there are cards in the card feeder.
Check that no cards are jammed in the printer.
- 6 Print a test card**
See elsewhere in this section for the procedure to be followed.

Blank card ejected

- 1 Check the ribbon**
Check that the ribbon is not finished or damaged. Replace it or re-install it if necessary.
- 2 The print head may be damaged**
Print a test card.



ICP 400

Poor print quality

Small blemishes on the card



- **The card surface may be dirty.**
Check that your cards are perfectly clean.
Use new cards.
- **Cleaning roller or print head clogged.**
Run a cleaning cycle.

Horizontal white lines



- **The ribbon is not correctly fitted.**
Check that there are no wrinkles on the ribbon surface.
- **Print head dirty or damaged.**
Clean or replace the print head.

Blurred image

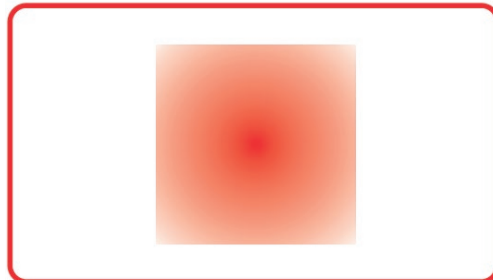

- **The ribbon is not correctly fitted.**
Check that the ribbon is correctly positioned in the printer.
- **Poor ribbon synchronisation.**
Open and close the printer cover to synchronise the ribbon.
- **Dirty printer or cleaning roller.**
Clean the printer.
- **Use of incompatible cards.**
Check that the cards used match the specifications.



We recommend that you obtain your cards from Altec.

Use of cards obtained elsewhere is liable to adversely affect print quality and/or damage the print head.



ICP 400

Partial or incorrect printing

- 1 Check the print settings**

Check that no area of the card design to be printed is outside the print margins.
Check the document orientation (portrait or landscape) in the Evolis Print Center configuration.
- 2 Check the interface cable**

If irregular characters are printed, check that you are in fact using the USB cable supplied with your printer.
Check the connection between the computer and the printer.
Try using another cable of the same type.
- 3 Check that the printer is clean**

Clean the printer, especially the cleaning roller.
See the maintenance section.
- 4 Check that the cards are clean**

Store your cards protected from dust.
- 5 Check the ribbon**

Check that the ribbon is fitted correctly.
Check that the ribbon spools freely.
- 6 Check the print head**

Should horizontal straight lines appear on printed cards, it is likely that the print head is dirty or damaged.



Freeing jammed cards

Control panel displays:



MECHANICAL ERROR

- Card jammed in the printer. Print jobs are interrupted.



Do not turn your printer off, as this cancels pending print jobs in the printer's memory.

Remove the card as follows:

- 1 Open the printer cover and remove the ribbon.
- 2 Press the pushbutton to activate the card feed rollers. If the card is still stuck inside the printer, slide it manually towards the printer output. If there is more than one card, always push the top one first.
- 3 Replace the ribbon, then close the printer cover.

To prevent card jams:

- 1 Check that the card thickness gauge is correctly adjusted.
- 2 Check that the cards are flat. Keep them in a horizontal position.
- 3 Check that the cards are not stuck together. Shuffle the cards before loading them.



ICP 400

Replacing the print head

The print head is a sensitive component of your equipment. It determines the print quality, and regular servicing along with an immediate environment free from dust or other particles ensure a lengthy useful life. Nonetheless, the print head may sometimes need to be replaced. Altec has designed a unique device enabling users to undertake such replacement with no tools needed, simply by following the instructions very carefully. Before doing anything else, please contact Altec in order to check the advisability of replacing the print head. The dealer will supply a new print head if need be.



For more information on print head warranties, please contact Altec.



ICP 400

To exchange the print head, please proceed as follows:

Before changing the print head, unplug the power cable.

Step 1 – Removing the defective print head

- 1 Open the printer cover.
- 2 Locate the print head.
- 3 Press on the plastic part behind the head (pressure plate) and pull on the head with the other hand as shown in the diagram in order to free the lugs from the holding fork, then remove the lugs from their slots.
- 4 Tilt the head carefully downwards and disconnect the connector linked to the cable without forcing the mechanism.

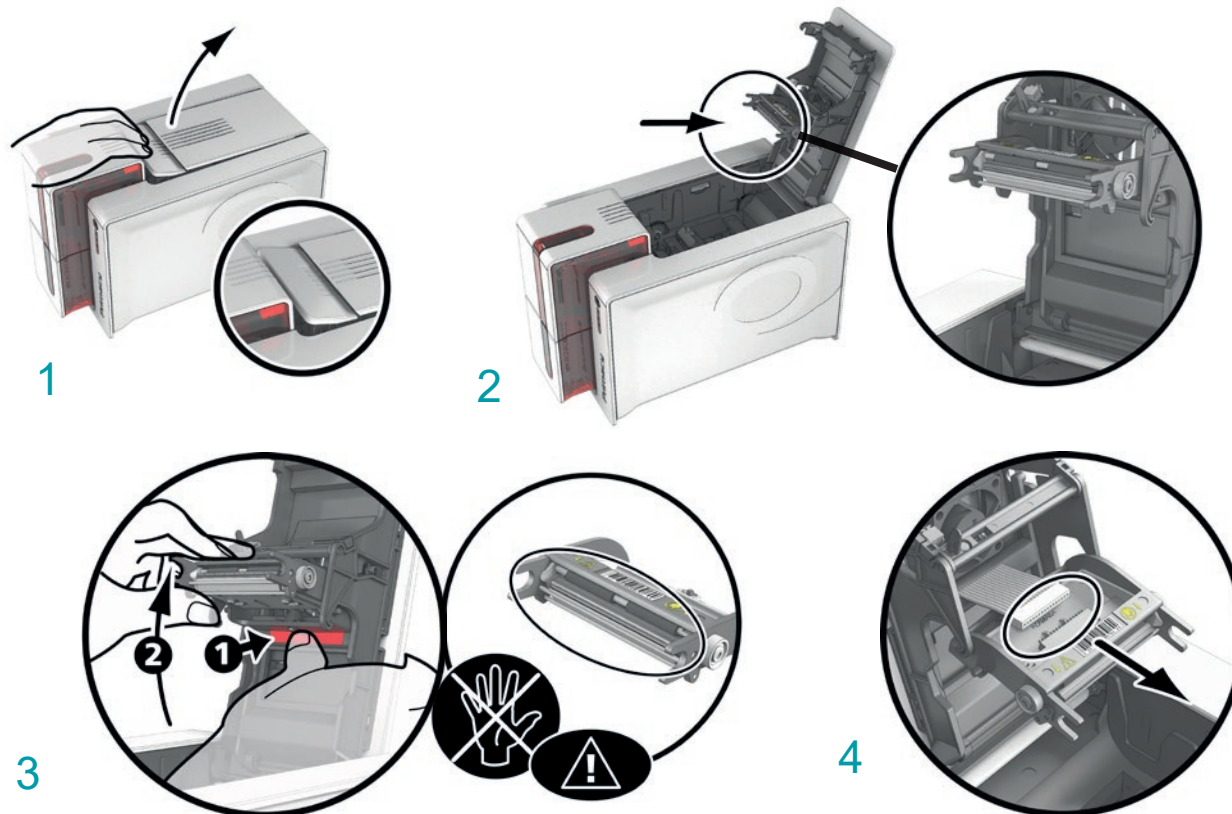



ICP 400

Step 2 – Installing the new print head

- 1 Note the code shown on the white label stuck on the print head. You will be asked for this code in Step 3.
- 2 Take the new head and insert it vertically (white connector upwards), raising it in the two guides so as to trap the lugs of the fork in their slots **1**. Then lower it by pressing on the two forks **2**, a click will be heard.
- 3 Connect the cable into its socket, making sure it is the right way round. Do not use any force, as this part is relatively fragile. Press down on each side of the connector to ensure a good connection is made.
- 4 The head is back in position.
- 5 Close the cover. The print head is now fitted.

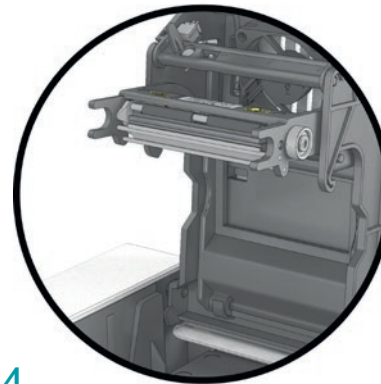
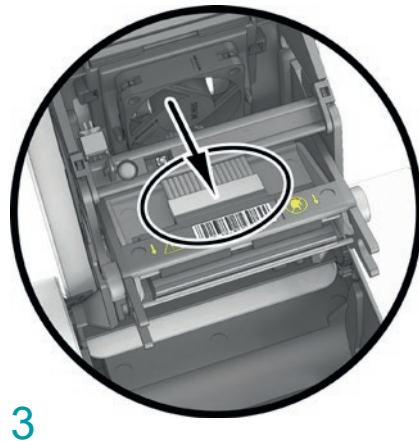
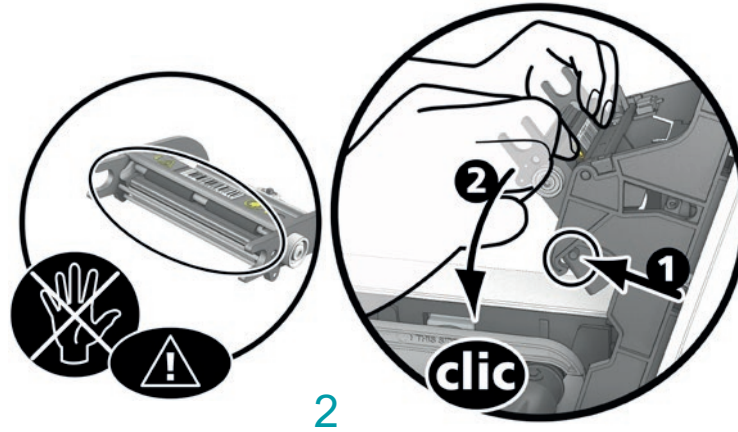
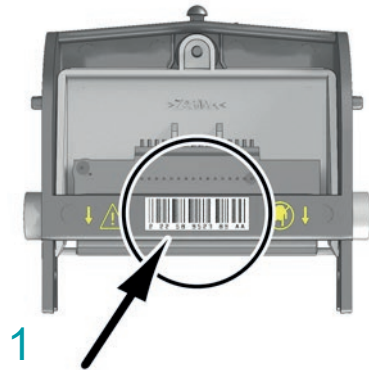



Step 3 – Configuring the new print head

- 1 Power up the printer and check that it is properly connected to a computer on which the printer's Evolis Print Center is installed.
- 2 Under **Maintenance** in Evolis Print Center, click on the **Change print head** tab.
- 3 Enter the PKN number of the print head kit in **Enter PKN No.**, the number you noted down in step 2. Then click **Confirm**.



If the print head kit number is not entered correctly, printer malfunctions may occur and the warranty may be voided.

Step 4 – Cleaning the printer

On your printer's control panel, the "**CLEANING**" light is lit:



CLEANING



Cleaning is absolutely necessary after changing the print head. No print jobs can be run until the cleaning operation has finished.

Once cleaning has been carried out, your printer is once again ready to customise your cards.



Wait for 2 minutes after cleaning before using your printer.